



Hurricane 900 XTT

Quick Guide

This guide is intended for quick consultation only and does not replace the user and maintenance manual. Before using this machine, read the user maintenance manual contained in the machine's packaging and follow all the instructions.

PREPARATION AND OPERATION

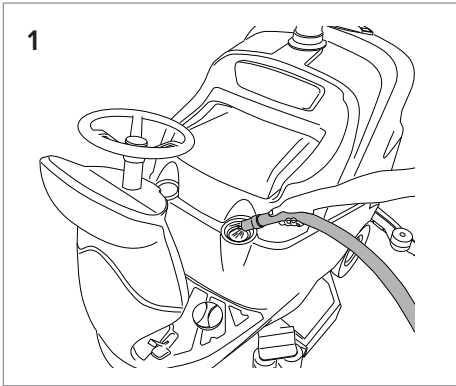

1 Add water and detergent to solution tank.

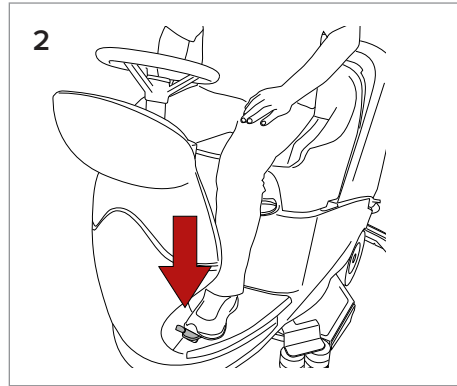

2 Disengage parking brake by pressing on the brake pedal.

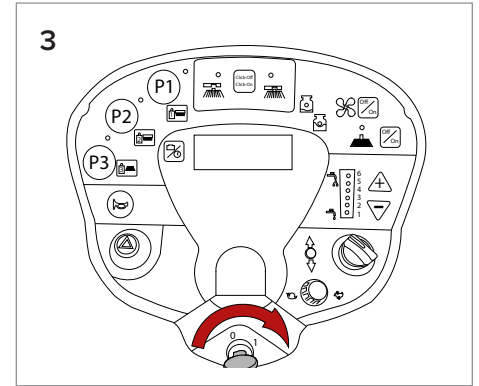

3 Power on.

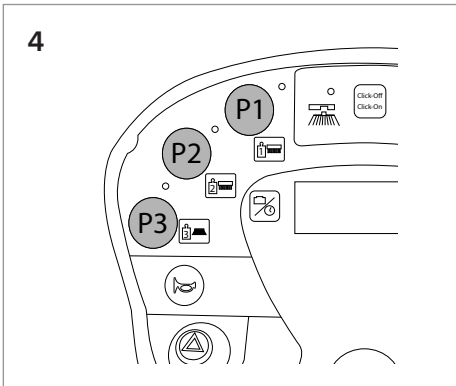

4 Select brush pressure setting.

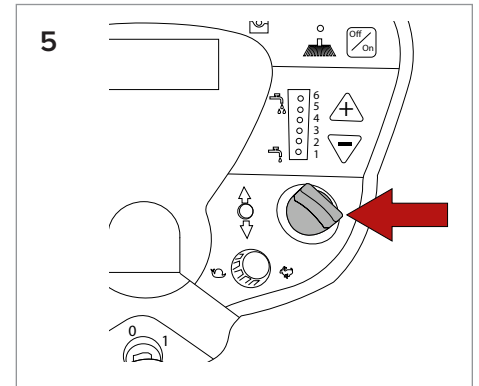
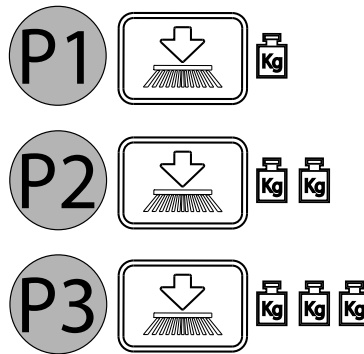

5 Toggle switch to change drive direction to forward or reverse.

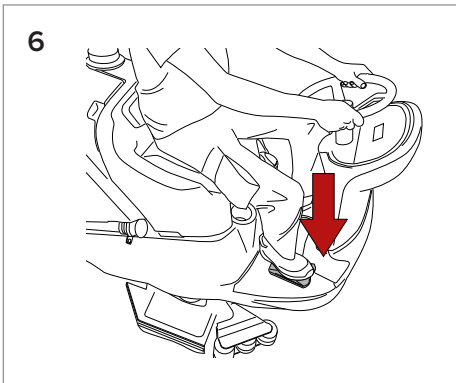

6 Press accelerator pedal to activate drive and scrubber.

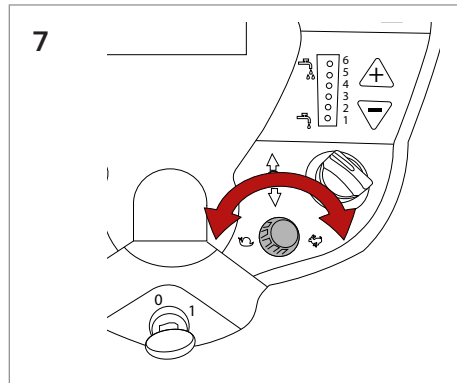

7 Turn to adjust travel speed.

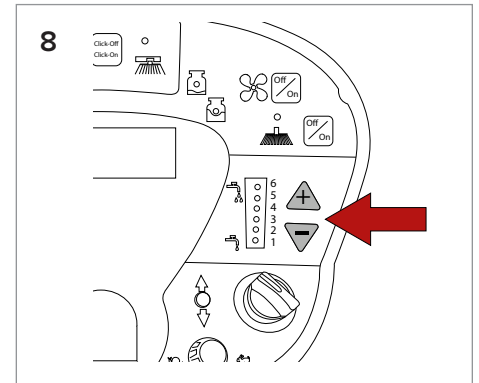

8 Press + or - to adjust water level.

DAILY MAINTENANCE

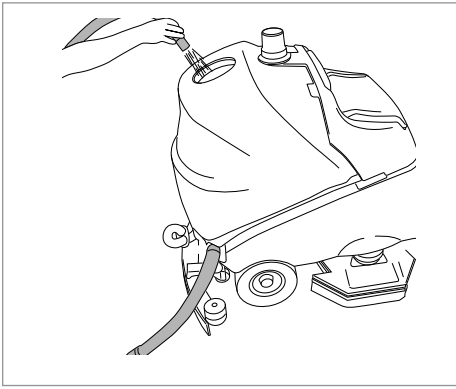

Clean the dirty water tank.

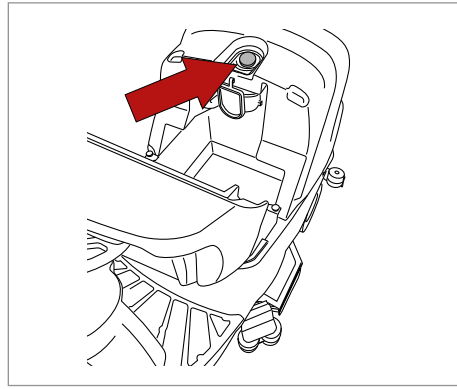

Make sure the suction filter and debris filter is clean and undamaged.

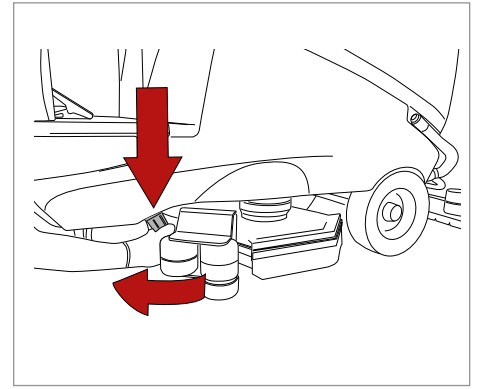

Make sure detergent outlet filter is clean and free of debris.

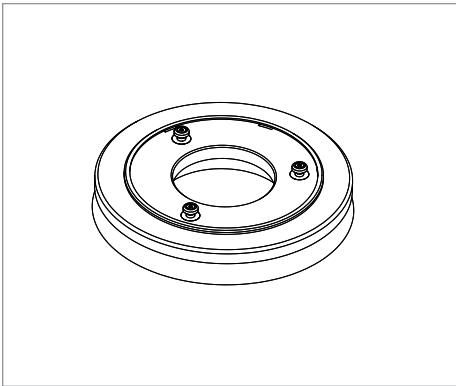

Make sure the brushes/drive pad are clean and not worn out. Replace if necessary.

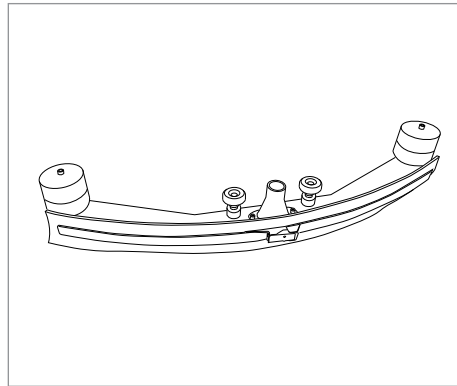

Make sure the squeegee is clean and the blades are not worn.

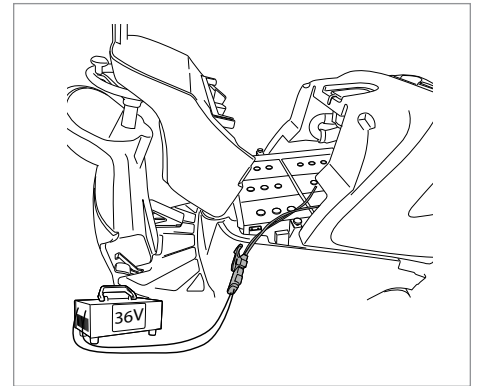

TO CHARGE BATTERIES

1. Disconnect battery pack from the machine.
2. Connect battery pack to the charger.
3. Plug in charger to power outlet.

NOTE: Never stop charge until cycle is complete (Green light).

REPLACING THE SQUEEGEE BLADES

Unscrew the wing nuts fixing the blade retainer.

Remove the blade retainer.

Remove the blade.

Put the same blade back, reversing the edge in contact with the floor, or replace with a new one.

Reposition the blade retainer and fix the wing nuts back.

ATTACHING/REMOVING THE BRUSHES

Attaching:

Press the CLICK ON-OFF button. The machine first performs a release operation, then immediately afterwards enables the attachment operation. Press the CLICK ON-OFF button again to automatically attach the brushes.

Removing:

Press the CLICK ON-OFF button, the machine releases the brushes.

