



Hurricane Maxi

Quick Guide

This guide is intended for quick consultation only and does not replace the user and maintenance manual. Before using this machine, read the user maintenance manual contained in the machine's packaging and follow all the instructions.

PREPARATION AND OPERATION

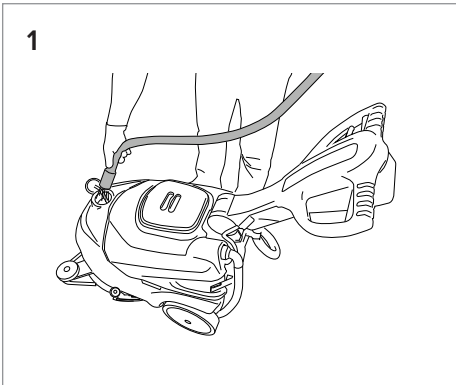

1 Add water and detergent to solution tank.

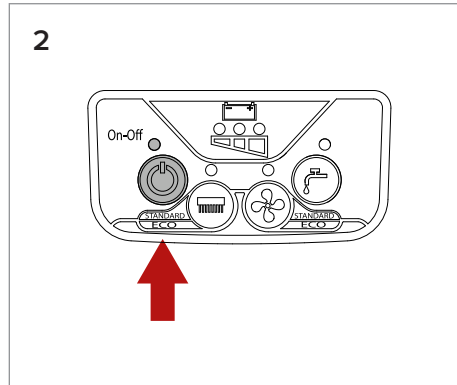

2 Power on.

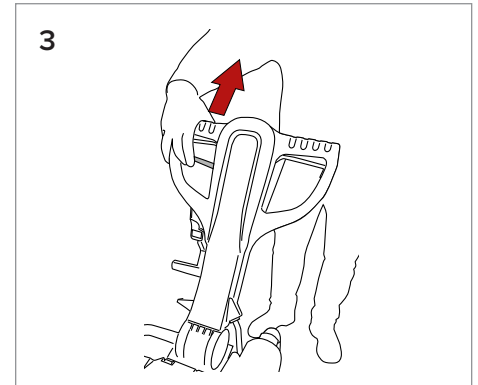

3 Pull up on lever to adjust the angle of the handle.

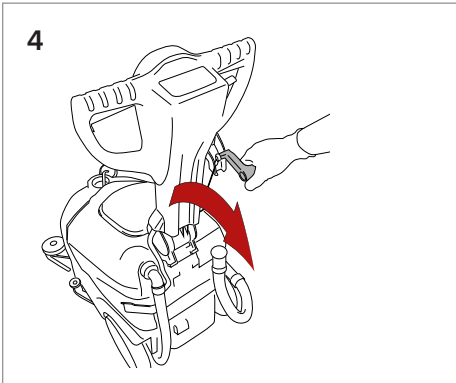

4 Pull squeegee lever to lower.

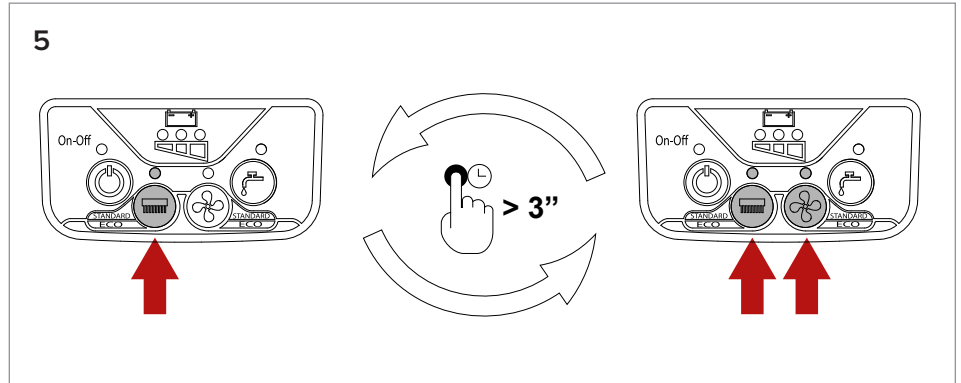

5 Press once to turn brush ON or OFF. Press and hold brush or Vacuum button for 3 sec. to turn ECO mode ON or OFF.

When ECO mode is activated, the Brush and Vacuum light will flash continuously. ECO mode reduces power of motor by 20% to reduce battery consumption.

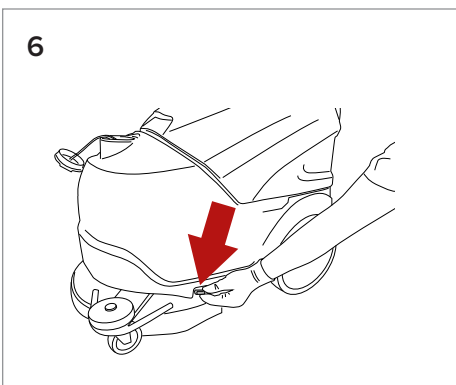

6 Turn valve manually to adjust water level.

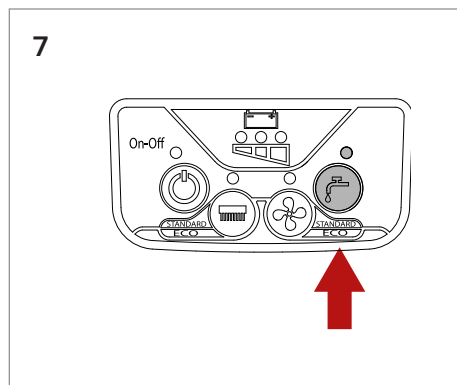

7 Press once to turn water ON or OFF.

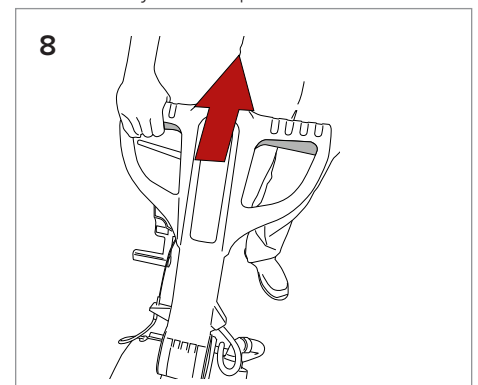

8 Pull lever to activate scrubber.

DAILY MAINTENANCE

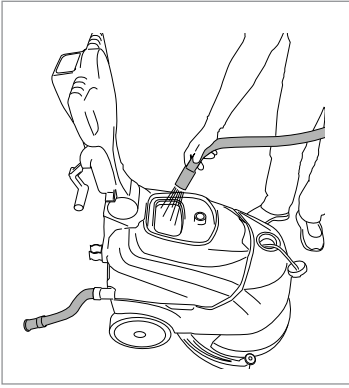

Clean the dirty water tank.

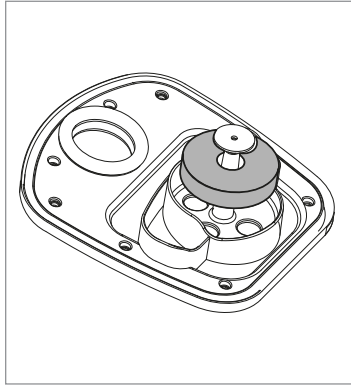

Make sure the dirty water tank float is undamaged and clean and moves freely on the pin.

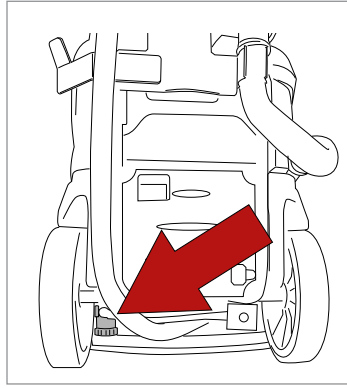

Make sure detergent outlet filter is clean and free of debris.

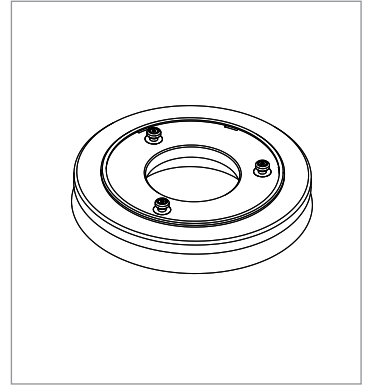

Make sure the pad driver is clean and not worn out. Replace if necessary.

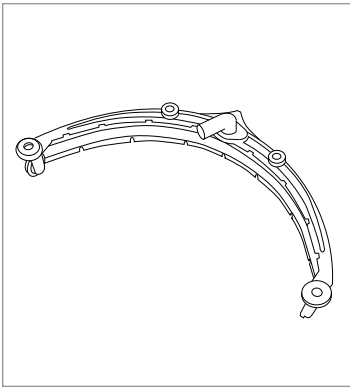

Make sure the squeegee is clean and the blades are not worn.

TO CHARGE BATTERIES

Plug in On Board charger to charge batteries if equipped.

NOTE: Never stop charge until cycle is complete (green light).

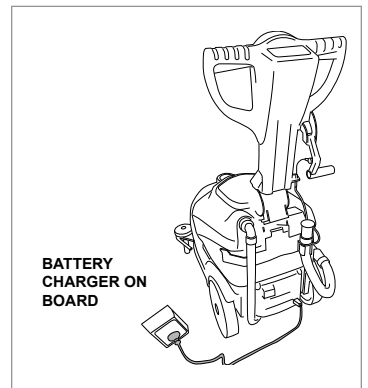

REPLACING THE SQUEEGEE BLADES

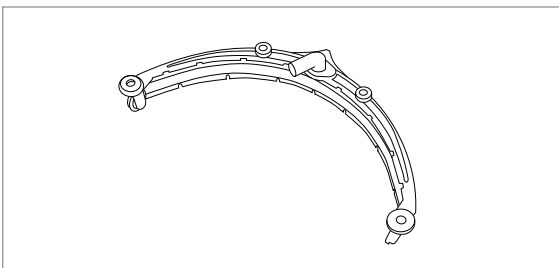

Unscrew the wing nuts fixing the blade retainer.

Remove the blade retainer.

Remove the blade.

Put the same blade back, reversing the edge in contact with the floor, or replace with a new one. Reposition the blade retainer and fix the wing nuts back.

ATTACHING/REMOVING THE PAD DRIVER

Position the pad driver underneath the head, in the centre (single-brush floor scrubber), position the pad driver underneath the head on both sides (double brush scrubber), switch the machine on.

Press the **ON-OFF** switch, once after starting the machine releases pad driver attachment. The button is only enabled when all the functions are deactivated (suction motor and pad driver).